

### Le nostre officine

### I nostri macchinari



Torni tradizionali OM1



Frese tradizionali OM2



Torni tradizionali OM2



Tornio automatico CNC



Fresa automatica CNC



Trapani a colonna OM1

### Il PCTO svolto nelle aziende del territorio



GRUPPO BOSSONI AUTOMOBILI

TECNOPEA

Nel rispetto della normativa vigente l'alternanza si configura come una strategia-metodologia formativa capace di integrare attività formative in aula e laboratorio con esperienze svolte nella concreta realtà di impresa.



DELMEC



Ljunghall



Spesso aziende del territorio in cui gli alunni svolgono esperienze di alternanza ci chiedono dei nominativi per **assunzioni**

La figura più richiesta è quella del **diplomato quinquennale in ambito meccanico**.

### Il nostro partner per il post diploma



### Alcuni dei nostri lavori ... dal progetto al prodotto

#### Scacchiera

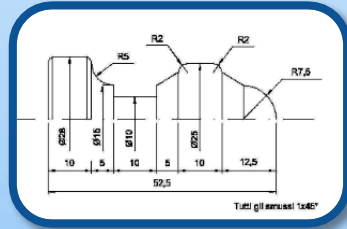
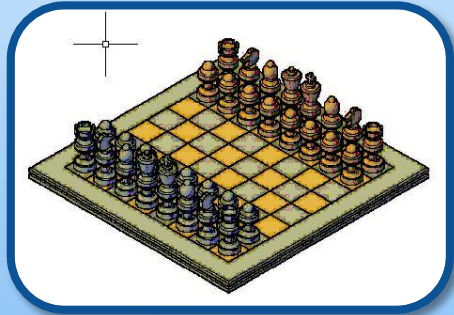

- N00 P05 PEDONE
- N20 G90 G96 T12.12 S200 F0.10 M04
- N30 SM2500
- N40 G00 X28 Z3
- N50 G01 Z-53
- N60 G00 X33
- N70 Z3
- N80 X26
- N90 G01 Z-42
- N100 X30
- N110 G00 Z3
- N130 G92 X8
- N140 L01.03
- N150 G92 X6
- N160 L01.03
- N170 G92 X4
- N180 L01.03
- N190 G92 X2
- N200 L01.03
- N210 G92 X0

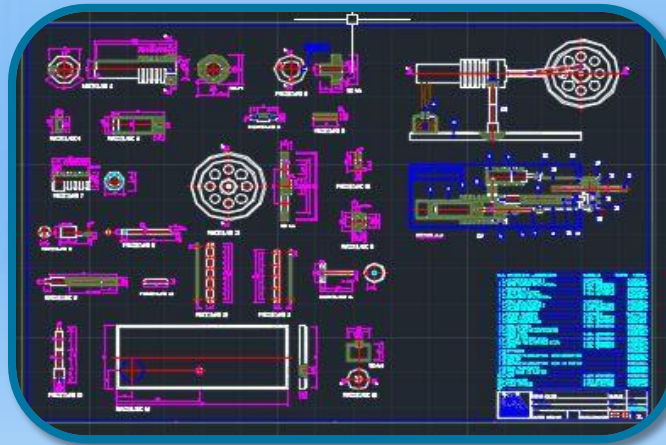

#### Motore Stirling

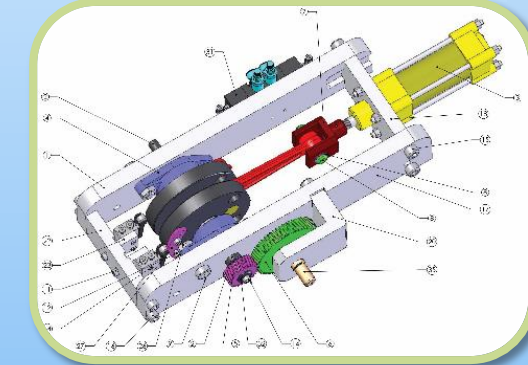

#### Motore pneumatico

